

SCS-102

INSPIRE

SMITH CAGE SYSTEM OPTION-1
ASSEMBLY AND OPERATION MANUAL

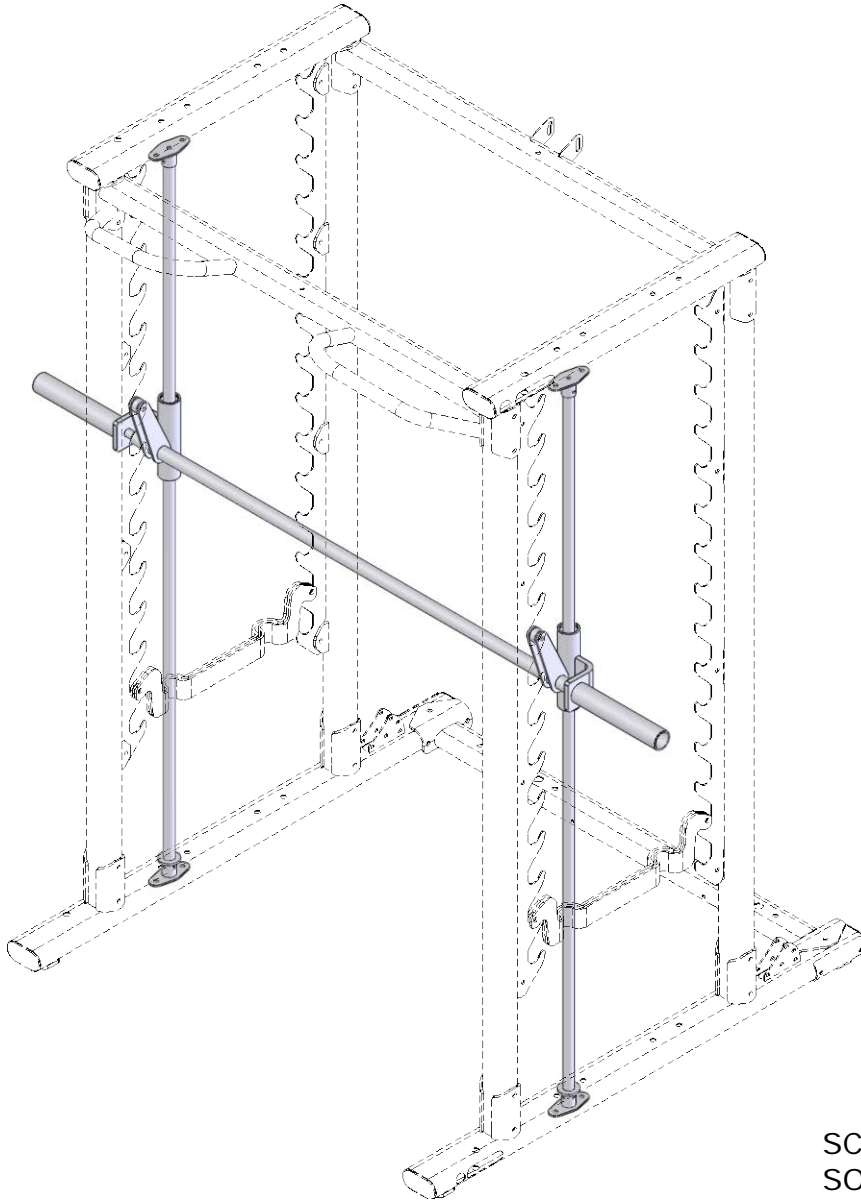

SCS-002 SMITH CAGE
SOLD SEPARATELY

RECORD SERIAL NUMBER HERE

CONGRATULATIONS... You've just taken the first step to a healthier and stronger body. This Smith Cage System Option-1 by Inspire Fitness offers the key to unlocking your body's potential. Regular strength training has been shown to deliver a host of benefits including: increased muscle tone, decreased body fat, improved energy levels, a reduction in stress, and improved cardiac output. Once again, congratulations, you are on your way to improving your self image, overall health, and quality of life.

BEFORE ASSEMBLING YOUR HOME GYM

CAUTION: Two people are required to assemble the Smith Cage System Option-1 to ensure that parts do not fall that could result in injury to the persons assembling the gym.

IMPORTANT: Read this entire manual before attempting to build or use this equipment. This manual contains step by step instructions for proper assembly.

Use the parts list included in this manual to verify that all parts are accounted for before assembly. If any parts are missing, contact the retailer of this Smith Cage System for replacement parts. Or, call Inspire Fitness at 877-738-1729.

Make sure that adequate room has been cleared before attempting to build your Smith Cage System Option-1. A rubber mat is recommended for use under your Smith Cage System to protect wood flooring or carpeting from damage during assembly and usage.

The Smith Cage System is intended for indoor use only. In addition, garages and screened in porches are not recommended due to high humidity or dust. Rust could form on certain parts, including linear bearing shafts, in a humid environment resulting in impaired function.

Service of your Smith Cage System should only be performed by an authorized Inspire Fitness retailer. Service performed by anyone else can result in loss of warranty. If you need help finding an authorized retailer, please contact us directly:

Inspire Fitness
4945 East Hunter Avenue
Anaheim, CA 92807
Ph: 877-738-1729
Fx: 714-738-1728
www.inspirefitness.net

TABLE OF CONTENTS

Section Description	Page
Important Safety Instructions.....	1
Tools Required.....	1
Parts & Hardware List.....	2
Assembly Instructions.....	3
Exploded View.....	5
General Maintenance Information and Schedule.....	6
Limited Warranty.....	7

IMPORTANT SAFETY INSTRUCTIONS

Please read this entire manual and familiarize yourself with all decals and warnings before using this Smith Cage System Option-1.

- **WARNING!** It is necessary to inspect this Smith Cage System Option-1 regularly to maintain safety and proper function. Please use the maintenance schedule included towards the back of this manual. Immediately replace any and all defective or worn parts. Pay special attention to moving parts. See General Maintenance section for complete details.
- Use this Smith Cage System Option-1 for its intended purpose as described in this Operation Manual or the exercise chart. Do not use attachments not recommended by the manufacturer.
- Make sure bystanders are at least 5 feet away from the Smith Cage System Option-1 while it is in use.
- Keep children away from the Smith Cage System Option-1 at all times.
- Keep the Smith Cage System Option-1 away from walls and clear of any obstructions and furniture.
- Stop immediately if you experience shortness of breath, pain, or dizziness during your workout. Inspire Fitness strongly recommends consulting your doctor before starting an exercise program.

TOOLS REQUIRED FOR ASSEMBLY

- 16mm wrench
- 3 mm Hex Key – supplied

PARTS & HARDWARE LIST

Item	Parts Description SCS-102 Box	Qty	Evs p/n
1	Weight Bar	1	
2	Weight Holder	2	
3	Linear Bearing shaft	2	
4	Top Shaft Mount	2	
5	Bottom Shaft Mount	2	

Item	Hardware Description SCS-102	Qty	Evs p/n
1	Bolt, M10 x 20 (Blue Dot)	8	
2	M10 Washer	8	
3	3 mm Hex Key	1	

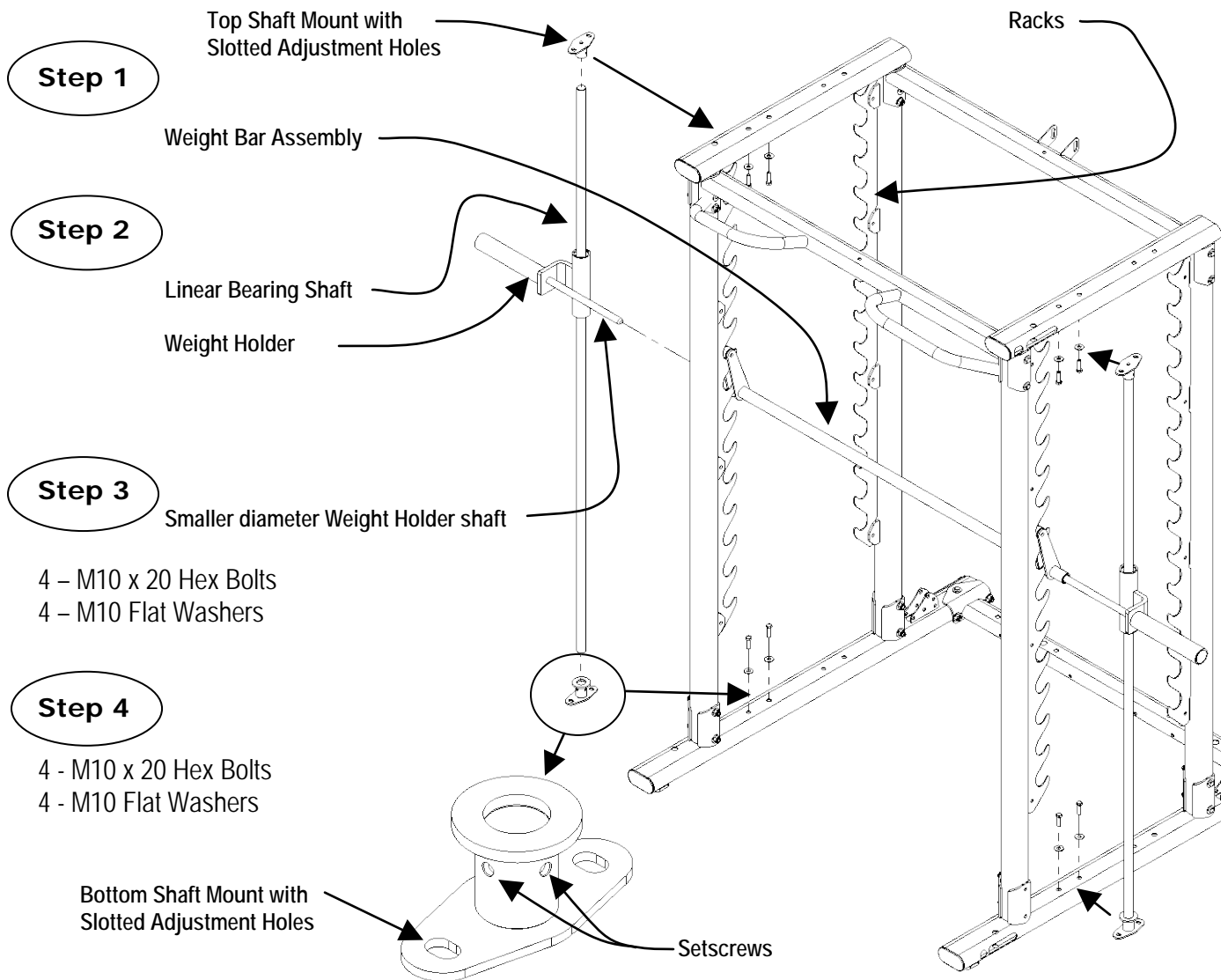

Step 1: Position the Red Weight Bar Assembly on the Hooks of the front Racks.

(NOTE: The SCS-102 can also be installed on the rear Racks as shown on the next page.)

Step 2: Slide a Linear Bearing shaft into one of the Weight Holders. Orient the Weight Holder as shown. Place a Bottom Shaft Mount onto the Shaft assuring it is fully seated and tighten the setscrews. Next, place a Top Shaft Mount on the Shaft before positioning it into the Cage (do not tighten Top Mount setscrews at this time)

Step 3: Gently guide the small diameter shaft of the Weight Holder into the Red Weight Bar Assembly and secure the Top and Bottom Shaft Mounts to the Cage using:

Four (M10 x 20 Hex Bolts)
Four (M10 Flat Washers)

(Finger Tighten Only)

Step 4: Repeat Steps 2 and 3 for the second side Linear Shaft and Weight Holder using:

Four (M10 x 20 Hex Bolts)
Four (M10 Flat Washers)

(Finger Tighten Only)

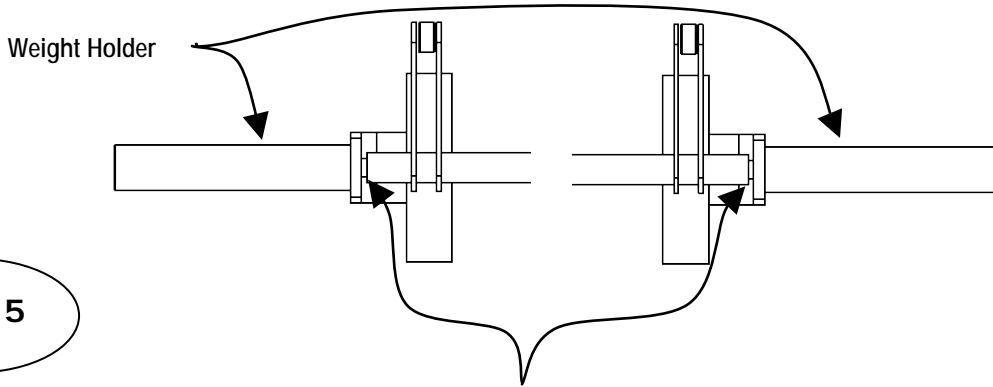

Step 5

Step 5: Adjust the spacing between the Weight Holders and the ends of the Red Weight Bar Assembly by moving the Linear Bearing Shafts in or out (using the adjustment slots in the Top and Bottom Shaft Mounts) before final tightening of the bolts. These components should not rub or bind when working out.

(Wrench Tighten Everything Now)

To attach the SCS-102 Option to the rear Racks, repeat steps 1 thru 5 using the rear set of mounting holes as shown below.

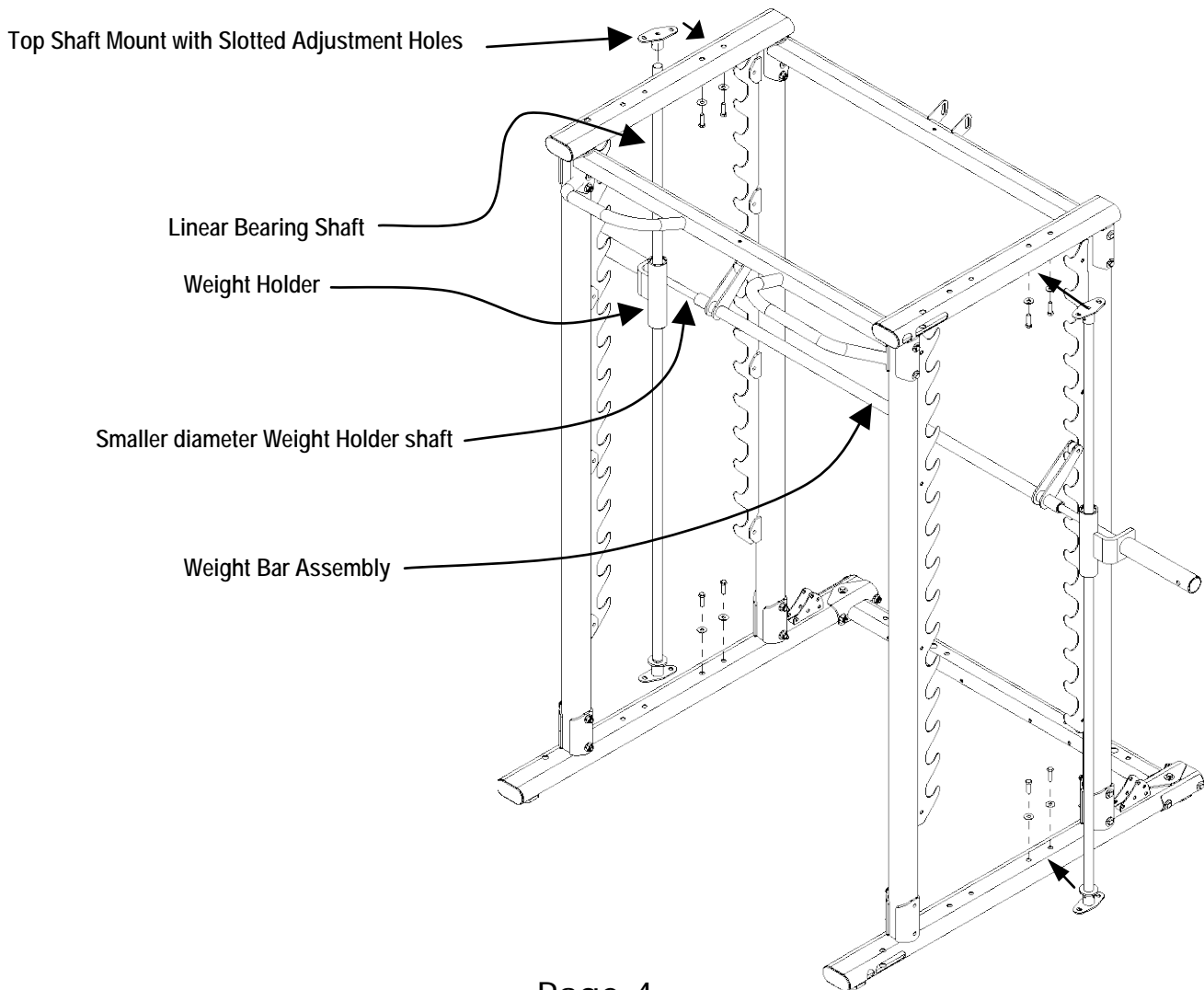

EXPLODED VIEW

Exploded View not available at this time.

Please contact customer service at 1-877-738-1728 for assistance or a copy.

Training Tips

CONSULT A PHYSICIAN BEFORE STARTING ANY EXERCISE PROGRAM

1. **Always warm up** before you start weight training. This helps get your muscles warm and prevents injury. You can warm up with light cardio or by doing a light set of each exercise before going to heavier weights.
2. **Control the weight.** Always work with a weight that you can handle through a full range of motion. Slow and steady movements are recommended.
3. **Breathe.** Don't hold your breath during your set. Holding your breath builds internal pressure which increases your change for broken blood vessels, as well as a hernia.
4. **Sit up straight.** Pay attention to your posture and keep everything straight. Engage your abs in every movement to keep balanced and protect your spine.

GENERAL MAINTENANCE INFORMATION AND SCHEDULE

- Regularly inspect product for loose hardware, wear, or damaged hardware or parts. If wear or damage exists, replace immediately.
- Do not use or store equipment outdoors.
- Locate and familiarize yourself with all warning decals on the home gym.
- Periodically wipe down Linear Shafts with a dry cloth and re-apply a thin coat of a teflon-based lubricant.

ROUTINE	HOME MAINTENANCE	ENTRY DATE								
Inspect: All Nuts and Bolts. Tighten if Needed	3 MONTHS									
Clean and Lubricate: Linear shafts with a Teflon based lubricant	3 MONTHS									
Inspect: All Decals	3 MONTHS									
Clean and Wax: All Glossy Finishes	YEARLY									

INSPIRE

Warranty.

This Warranty applies to Inspire Strength products manufactured or distributed by Health In Motion LLC.

CONSUMER USE:

LIMITED LIFETIME FRAME:

Includes Frame and Welds

LIMITED LIFETIME PARTS:

Includes Upholstery, Hardware, etc.

LIMITED LIFETIME MOVING PARTS:

Includes Pulleys, Cables, etc.

LIGHT-COMMERCIAL USE:

LIMITED LIFETIME FRAME:

Includes Frame and Welds

10 YEAR PARTS:

Includes Upholstery, Hardware, etc.

10 YEAR MOVING PARTS:

Includes Pulleys, Cables, etc.

PLEASE NOTE THAT NOT ALL INSPIRE PRODUCTS ARE MADE FOR LIGHT-COMMERCIAL USE

Refer to your Owner's Manual or consult with you fitness product dealer to establish if a Product is made for light-commercial use or not. Using a non-commercial product in a commercial setting can result in serious injury or death!

Health In Motion warrants that the Product you have purchased for light-commercial, personal, family or household use from Health In Motion LLC or from an authorized Health In Motion reseller is free from defects in materials or workmanship under normal use during the warranty period. Your sales receipt, showing the date of purchase of the Product, is your proof of the date of purchase. This warranty extends only to you, the original purchaser. It is not transferable to anyone who subsequently purchases the Product from you. It excludes expendable parts such as paint and finish. This Warranty becomes VALID ONLY if the Product is assembled / installed according to the instructions / directions included with the Product.

Replacement and repair of parts.

During the warranty period Health In Motion will, at no additional charge, repair or replace the Product if it becomes defective, malfunctions, or otherwise fails to conform with this Warranty under normal light-commercial, personal, family, or household use. In repairing the product Health In Motion may replace defective parts with, at the option of Health In Motion, serviceable used parts that are equivalent to new parts in performance, or new parts. All exchanged parts and Products replaced under this warranty will become the property of Health In Motion. Health In Motion reserves the right to change manufacturers and or specification of any part to cover any existing warranty.

Service procedures.

To obtain warranty parts, you must return the parts to Health In Motion or an authorized Health In Motion retailer in its original container (or equivalent). You must pre-pay any shipping charges, taxes, or any other charges associated with transportation of the Product. In addition, you are responsible for insuring any Product shipped or returned. You assume the risk of loss during shipment. You must present Health In Motion with proof-of-purchase documents (including the date of purchase, Model, and Serial Number). Any evidence of alteration, erasing or forgery of proof - of-purchase documents will be cause to void this Warranty. Register your warranty online visit www.inspirefitness.net

Conditions and Exceptions.

This Warranty does not extend to any Product not purchased from Health In Motion LLC or from an authorized Health In Motion reseller. This Warranty does not extend to any Product that has been damaged or rendered defective; (a) as a result of accident, misuse, or abuse; (b) by the use of parts not manufactured or sold by Health In Motion; (c) by modification of the Product; (d) as a result of service by anyone other than Health In Motion, or an authorized Health In Motion warranty service provider; (e) product that has not been properly maintained (follow maintenance schedule found on product). Should any product submitted for Warranty service be found to be ineligible, an estimate of repair cost will be furnished and the repair will be made if requested by you upon Health In Motion receipt of payment or acceptable arrangement of payment.

Disclaimer

EXCEPT AS EXPRESSLY SET FORTH IN THIS WARRANTY HEALTH IN MOTION MAKES NO OTHER WARRANTIES; EXPRESSED OR IMPLIED INCLUDING ANY IMPLIED WARRANTIES OF MERCHANTABILITY AND FITNESS FOR A PARTICULAR PURPOSE. HEALTH IN MOTION EXPRESSLY DISCLAIMS ALL WARRANTIES NOT STATED IN THIS WARRANTY. ANY IMPLIED WARRANTIES THAT MAY BE IMPOSED BY LAW ARE LIMITED TO THE TERMS OF THIS WARRANTY. NEITHER HEALTH IN MOTION NOR ANY OF ITS AFFILIATES SHALL BE RESPONSIBLE FOR INCIDENTAL OR CONSEQUENTIAL DAMAGES. HEALTH IN MOTION IS NOT RESPONSIBLE FOR THE REPAIR OR REPLACEMENT OF ANY PARTS THAT HEALTH IN MOTION DETERMINES HAVE BEEN SUBJECTED AFTER THE DATE OF MANUFACTURE TO ALTERATION, NEGLIGENCE, ABUSE, MISUSE, NORMAL WEAR & TEAR, ACCIDENT, DAMAGE DURING TRANSIT OR INSTALLATION, FIRE, FLOOD, OR ANY ACT OF GOD. SOME STATES DO NOT ALLOW LIMITATIONS ON HOW LONG AN IMPLIED WARRANTY LASTS OR THE EXCLUSION OR LIMITATION OF INCIDENTAL OR CONSEQUENTIAL DAMAGES, SO THE ABOVE LIMITATIONS OR EXCLUSION MAY NOT APPLY TO YOU. This Warranty gives you specific legal rights and you may also have other rights that may vary from state to state. This is the only express warranty applicable to Health In Motion's "Inspire" branded strength products. Health In Motion neither assumes nor authorizes anyone to assume for it any other express warranty.